

**Features**

- 2-channel isolated barrier
- 24 V DC supply (Power Rail)
- Dry contact or NAMUR inputs
- Isolated passive transistor output, TTL level
- Line fault detection (LFD)
- Reversible mode of operation

**Function**

This isolated barrier is used for intrinsic safety applications. It transfers digital signals (NAMUR sensors/mechanical contacts) from a hazardous area to a safe area.

Each proximity sensor or switch controls a passive transistor output for the safe area load. Both transistor outputs are isolated from each other and isolated from the power supply. The normal output state can be reversed using switch S1 for channel I and switch S2 for channel II. Switch S3 enables or disables line fault detection of the field circuit.

During an error condition, the transistors revert to their de-energized state and LEDs indicate the fault according to NAMUR NE44.

A unique collective error messaging feature is available when used with the Power Rail system.

**Assembly**

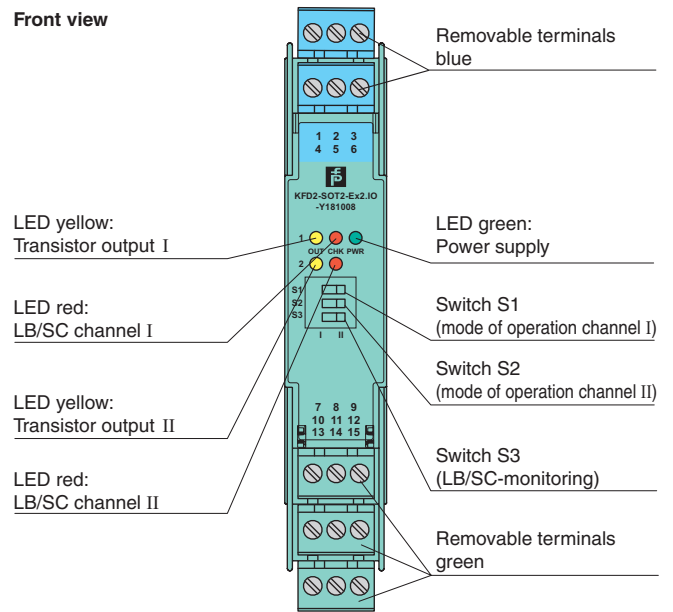

**Connection**

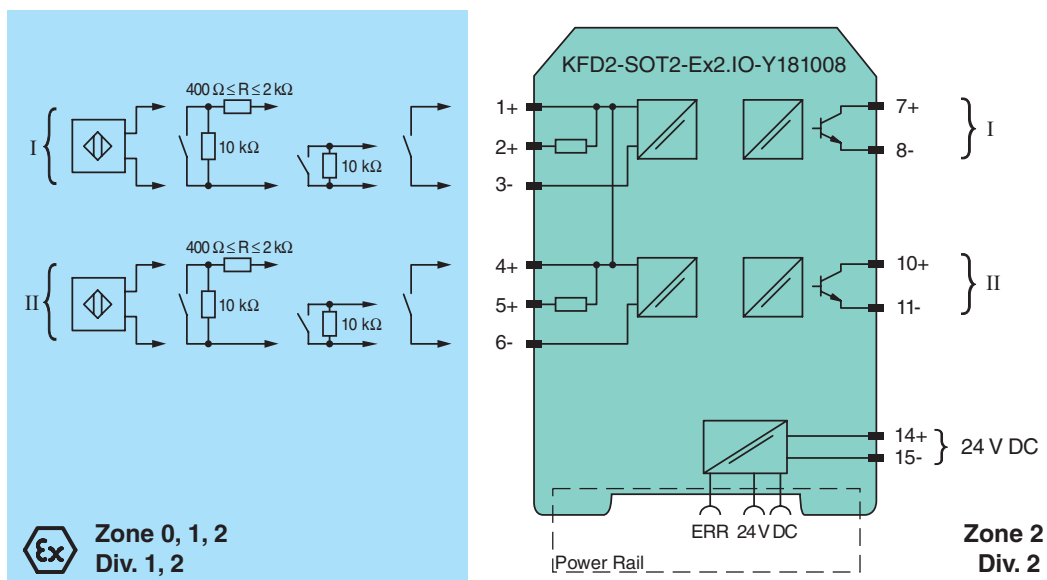

Release date 2019-01-25 09:38 Date of issue 2019-01-25 181008\_eng.xml

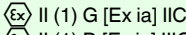
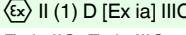
|  |       |  |
|--|-------|--|
| <b>General specifications</b>                                  |       |  |
| Signal type  |       | Digital Input  |
| <b>Supply</b>  |       |  |
| Connection   |       | Power Rail or terminals 14+, 15-   |
| Rated voltage  | $U_r$ | 20 ... 30 V DC   |
| Ripple   |       | ≤ 10 %   |
| Rated current  | $I_r$ | ≤ 50 mA  |
| <b>Input</b>   |       |  |
| Connection side  |       | field side   |
| Connection   |       | terminals 1+, 2+, 3-; 4+, 5+, 6-   |
| Rated values   |       | acc. to EN 60947-5-6 (NAMUR), see system description for electrical data   |
| Open circuit voltage/short-circuit current                     |       | approx. 8 V DC / approx. 8 mA  |
| Switching point/switching hysteresis                           |       | 1.2 ... 2.1 mA / approx. 0.2 mA  |
| Line fault detection   |       | breakage $I \leq 0.1$ mA , short-circuit $I > 6$ mA  |
| <b>Output</b>  |       |  |
| Connection side  |       | control side   |
| Connection   |       | output I: terminals 7+, 8- ; output II: terminals 10+, 11-   |
| Switching voltage  |       | ≤ 30 V   |
| Switching current  |       | ≤ 2 mA , short-circuit protected   |
| Signal level   |       | 1-signal: switching voltage - 0.85 V max. at 2 mA switching current<br>0-signal: switched off (off-state current ≤ 10 μA)  |
| Output I, II   |       | signal , TTL compatible  |
| Collective error message                                       |       | Power Rail   |
| <b>Transfer characteristics</b>                                |       |  |
| Switching frequency  |       | ≤ 5 kHz  |
| <b>Galvanic isolation</b>                                      |       |  |
| Input/Output   |       | reinforced insulation acc. to IEC 62103, rated insulation voltage 300 V <sub>rms</sub>   |
| Input/power supply   |       | reinforced insulation acc. to IEC 62103, rated insulation voltage 300 V <sub>rms</sub>   |
| Output/power supply  |       | basic insulation according to IEC 62103, rated insulation voltage 50 V <sub>eff</sub>  |
| Output/Output  |       | basic insulation according to IEC 62103, rated insulation voltage 50 V <sub>eff</sub>  |
| <b>Indicators/settings</b>                                     |       |  |
| Display elements   |       | LEDs   |
| Control elements   |       | DIP-switch   |
| Configuration  |       | via DIP switches   |
| Labeling   |       | space for labeling at the front  |
| <b>Directive conformity</b>                                    |       |  |
| Electromagnetic compatibility                                  |       |  |
| Directive 2014/30/EU   |       | EN 61326-1:2013 (industrial locations)   |
| <b>Conformity</b>  |       |  |
| Galvanic isolation   |       | IEC 62103:2003   |
| Electromagnetic compatibility                                  |       | NE 21:2004   |
| Degree of protection   |       | IEC 60529:2001   |
| Input  |       | EN 60947-5-6:2000  |
| <b>Ambient conditions</b>                                      |       |  |
| Ambient temperature  |       | -20 ... 60 °C (-4 ... 140 °F)  |
| <b>Mechanical specifications</b>                               |       |  |
| Degree of protection   |       | IP20   |
| Connection   |       | screw terminals  |
| Mass   |       | approx. 150 g  |
| Dimensions   |       | 20 x 119 x 115 mm (0.8 x 4.7 x 4.5 inch)   |
| Mounting   |       | on 35 mm DIN mounting rail acc. to EN 60715:2001   |
| <b>Data for application in connection with hazardous areas</b> |       |  |
| EU-Type Examination Certificate                                |       | PTB 00 ATEX 2035   |
| Marking  |       | <br> |
| Input  |       | Ex ia IIC, Ex ia IIIC  |
| Voltage  | $U_o$ | 10.5 V   |
| Current  | $I_o$ | 13 mA  |
| Power  | $P_o$ | 34 mW (linear characteristic)  |
| Supply   |       |  |
| Maximum safe voltage   | $U_m$ | 40 V DC (Attention! The rated voltage can be lower.)   |
| Type of protection [Ex ia and Ex ib]                           |       |  |
| Output   |       |  |
| Maximum safe voltage   | $U_m$ | 40 V DC (Attention! The rated voltage can be lower.)   |

Release date 2019-01-25 09:38 Date of issue 2019-01-25 181008\_eng.xml

|                                 |   |
|---------------------------------|---|
| EU-Type Examination Certificate | DMT 01 ATEX E 133   |
| Marking                         | ⊕ I (M1) [Ex ia] I  |
| Certificate                     | TÜV 99 ATEX 1499 X  |
| Marking                         | ⊕ II 3G Ex nA II T4   |
| Galvanic isolation              |   |
| Input/Output                    | safe electrical isolation acc. to IEC/EN 60079-11, voltage peak value 375 V   |
| Input/power supply              | safe electrical isolation acc. to IEC/EN 60079-11, voltage peak value 375 V   |
| Directive conformity            |   |
| Directive 2014/34/EU            | EN 60079-0:2012+A11:2013 , EN 60079-11:2012 , EN 60079-15:2010 , EN 50303:2000  |
| <b>International approvals</b>  |   |
| FM approval                     |   |
| Control drawing                 | 116-0035  |
| CSA approval                    |   |
| Control drawing                 | 116-0047  |
| IECEX approval                  |   |
| IECEX certificate               | IECEX PTB 05.0011   |
| IECEX marking                   | [Ex ia] IIC , [Ex ia] I , [Ex ia] IIIC  |
| <b>General information</b>      |   |
| Supplementary information       | Observe the certificates, declarations of conformity, instruction manuals, and manuals where applicable. For information see  |
| <b>Accessories</b>              |   |
| Optional accessories            | <ul style="list-style-type: none"> <li>- power feed module KFD2-EB2(.R4A.B)(.SP)</li> <li>- universal power rail UPR-03(-M)(-S)</li> <li>- profile rail K-DUCT-BU(-UPR-03)</li> </ul> |